

- 特点：导通电阻低 开关速度快 输入阻抗高 符合ROHS规范
- FEATURES: ■ LOW ON-RESISTANCE ■ FAST SWITCHING ■ HIGH INPUT RESISTANCE ■ ROHS COMPLIANT
- 应用：电子镇流器 电子变压器 开关电源 LED驱动器
- APPLICATION: ■ ELECTRONIC BALLAST ■ ELECTRONIC TRANSFORMER ■ SWITCH MODE POWER SUPPLY ■ LED DRIVER

- 最大额定值：(Tc=25°C)
- Absolute Maximum Ratings (Tc=25°C) TO-220F/TO-220

参数 PARAMETER	符号 SYMBOL	额定值 VALUE	单位 UNIT
漏-源电压 Drain-source Voltage	V _{DS}	650	V
栅-源电压 Gate-source Voltage	V _{GS}	±30	V
漏极电流 Continuous Drain Current Tc=25°C	I _D	10.0*	A
漏极电流 Continuous Drain Current Tc=100°C	I _D	6.0*	A
最大脉冲电流 Drain Current-Pulsed ①	I _{DM}	40*	A
耗散功率 Power Dissipation	P _D	65	W
最高结温 Junction Temperature	T _J	150	°C
存储温度 Storage Temperature	T _{STG}	-55-150	°C
单脉冲雪崩能量 Single Pulse Avalanche Energy ②	EAS	280	mJ

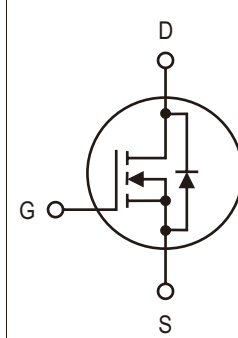

V_{DS}=650V

R_{DS(ON)typ.}=0.65Ω

I_D=10.0A

TO-220

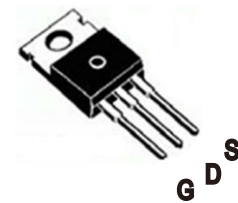

TO-220F

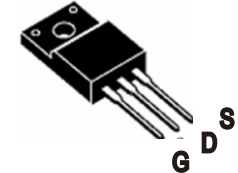

*漏极电流由最高结温限制
*Drain current limited by maximum junction temperature

- 热特性
- Thermal Characteristics

参数 PARAMETER	符号 SYMBOL	最小值 MIN	典型值 TYP	最大值 MAX	单位 UNIT
热阻结-壳 Thermal Resistance Junction-case	R _{thJC}			1.90	°C/W
热阻结-环境 Thermal Resistance Junction-ambient	R _{thJA}			62.5	°C/W

- 订购信息
- Ordering Information

产品型号 Order Code	产品丝印 Marking	封装外形 Package	包装形式 Packing	包装数量 packing quantity				
				50Pcs/Tube	20T/Box	1.0K/Box	5B/Carton	5K/Carton
SI10N65F	SI10N65F	TO-220F	Tube	50Pcs/Tube	20T/Box	1.0K/Box	5B/Carton	5K/Carton
SI10N65P	SI10N65P	TO-220P	Tube	50Pcs/Tube	20T/Box	1.0K/Box	5B/Carton	5K/Carton

Note: T: Tube/管 R: Reel/卷盘 B: Box/内盒 C: Carton/箱

- 电特性：(Tc=25°C)
- Electronic Characteristics (Tc=25°C)

参数 PARAMETER	符号 SYMBOL	测试条件 TEST CONDITION	最小值 MIN	典型值 TYP	最大值 MAX	单位 UNIT
漏-源击穿电压 Drain-source Breakdown Voltage	BV _{DSS}	V _{GS} =0V, I _D =250μA	650			V
击穿电压温度系数 Breakdown Voltage Temperature Coefficient	ΔBV _{DSS} /ΔT _J	I _D =250μA, Referenced to 25°C		0.65		V/°C
栅极开启电压 Gate Threshold Voltage	V _{GS(TH)}	V _{GS} =V _{DS} , I _D =250μA	3.0		4.0	V
漏-源漏电流 Drain-source Leakage Current	I _{DSS}	V _{DS} =650V, V _{GS} =0V, T _J =25°C			1	μA
		V _{DS} =520V, V _{GS} =0V, T _J =125°C			100	μA
栅极漏电流 Gate-body Leakage Current (V _{DS} =0)	I _{GSS}	V _{GS} =±30V			±100	nA
漏-源导通电阻 Static Drain-source On Resistance	R _{DS(ON)}	V _{GS} =10V, I _D =5.0A ③		0.65	0.80	Ω
输入电容 Input Capacitance	C _{iss}	V _{GS} =0V, V _{DS} =25V, F=1.0MHz		1294		pF
输出电容 Output Capacitance	C _{oss}			149		pF
反相转移电容 Reverse Transfer Capacitance	C _{rss}			18		pF
开启延迟时间 Turn-On Delay Time	T _{d(on)}	V _{DD} =325V, I _D =10.0A R _G =25Ω ③		23		ns
上升时间 Turn-On Rise Time	T _r			15		ns
关断延迟时间 Turn-Off Delay Time	T _{d(off)}			90		ns
下降时间 Turn-Off Fall Time	T _f			30		ns
栅极电荷 Total Gate Charge	Q _g	I _D =10.0A, V _{DS} =520V V _{GS} =10V ③		35		nC
栅源电荷 Gate-to-Source Charge	Q _{gs}			7		nC
栅漏电荷 Gate-to-Drain Charge	Q _{gd}			18		nC
二极管正向电流 Continuous Diode Forward Current	I _s				10.0	A
二极管正向压降 Diode Forward Voltage	V _{SD}	T _J =25°C, I _s =10.0A V _{GS} =,0V ③			1.4	V
反向恢复时间 Reverse Recovery Time	T _{rr}	T _J =25°C, I _f =10.0A di/dt=100A/μS ③		320		ns
反向恢复电荷 Reverse Recovery Charge	Q _{rr}			4.2		uC

注释 (Notes):

①脉冲宽度: 以最高结温为限制

Repetitive rating: Pulse width limited by maximum junction temperature

②初始结温=25°C, V_{DD}=50V, L=10mH, R_G=25Ω, I_{AS}=7.5A

Starting T_J=25°C, V_{DD}=50V, L=10mH, R_G=25Ω, I_{AS}=7.5A

③脉冲测试: 脉冲宽度≤300μs, 占空比≤2%

Pulse Test: Pulse width≤300μs, Duty cycle≤2%

● TEST CIRCUITS AND WAVEFORMS

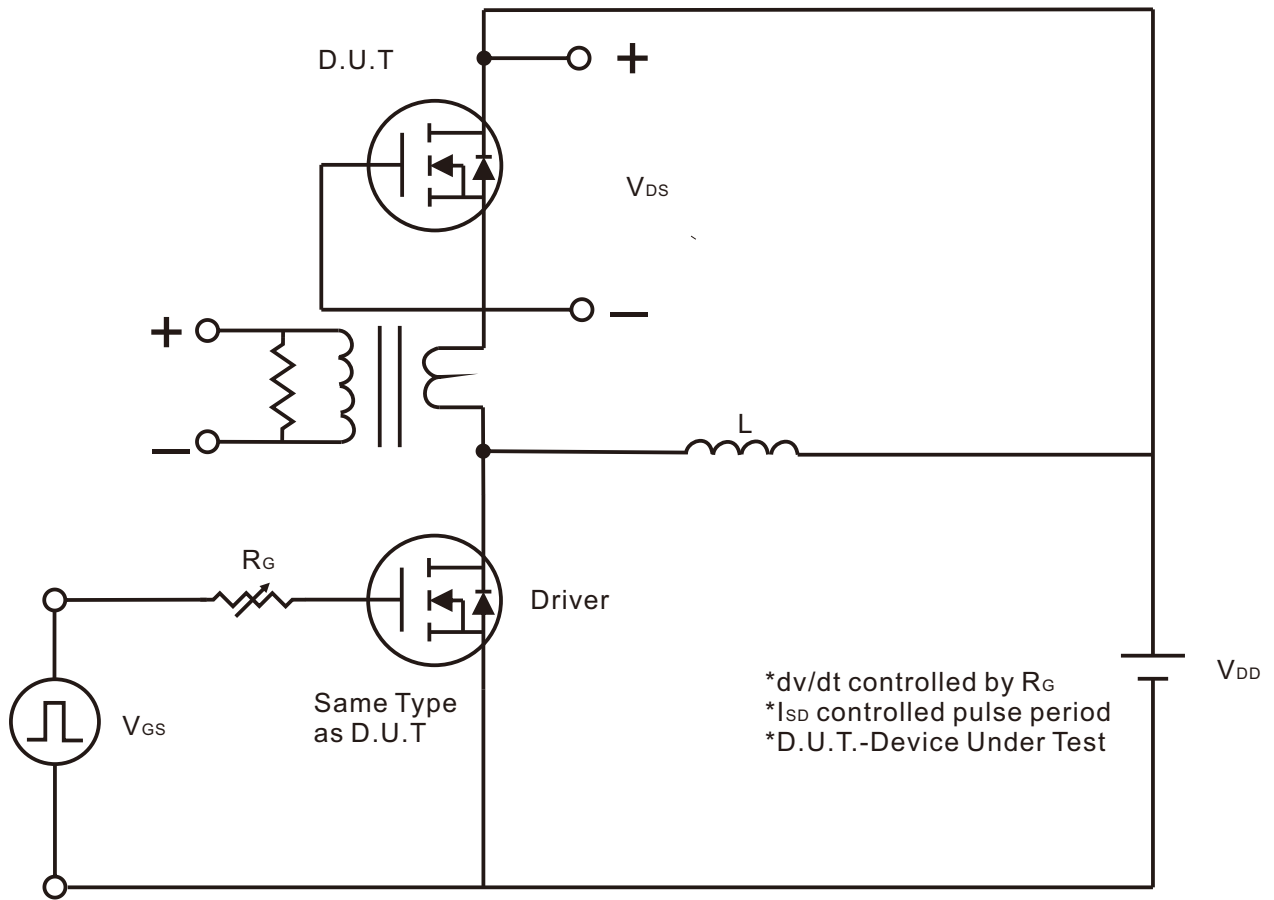

Peak Diode Recovery Test Circuit

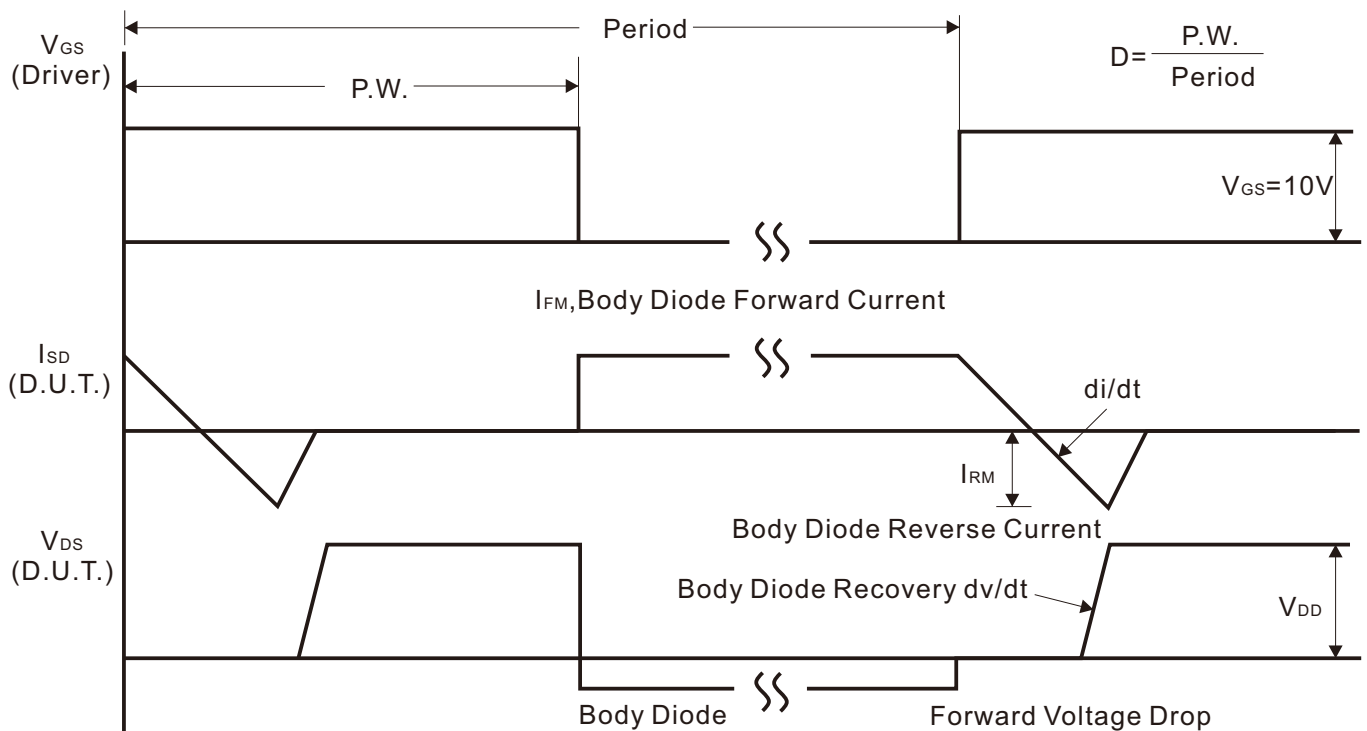

Peak Diode Recovery dv/dt Waveforms

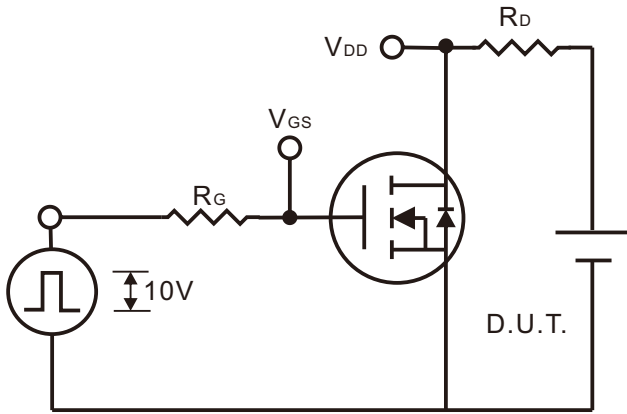

Switching Test Circuit

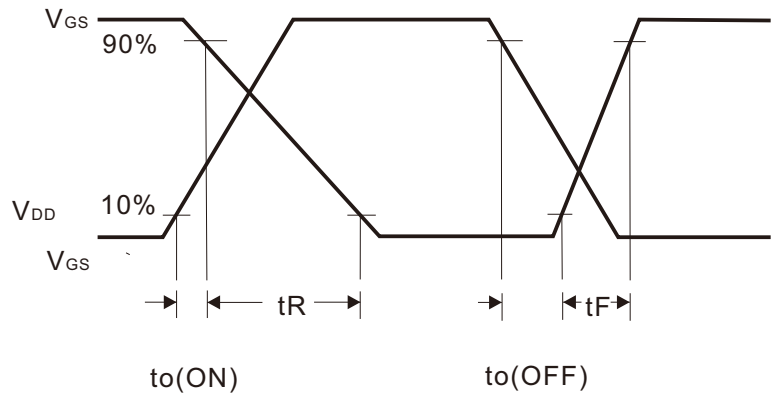

Switching Waveforms

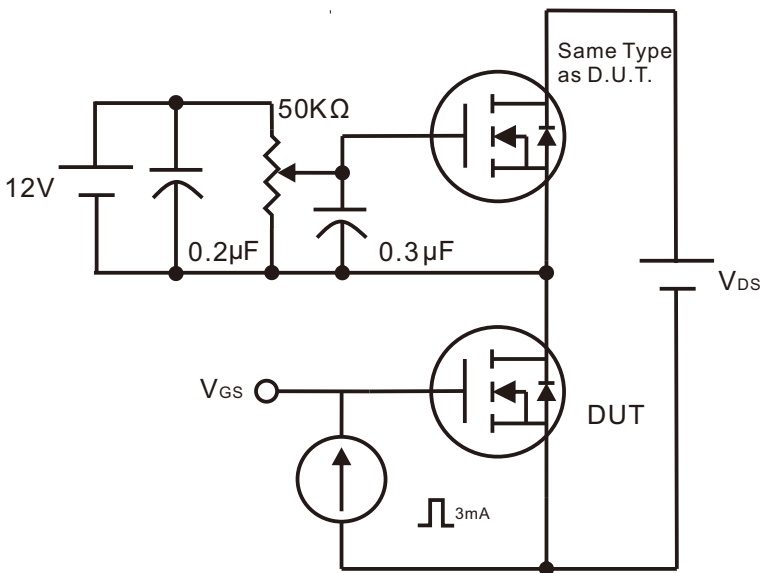

Gate Charge Test Circuit

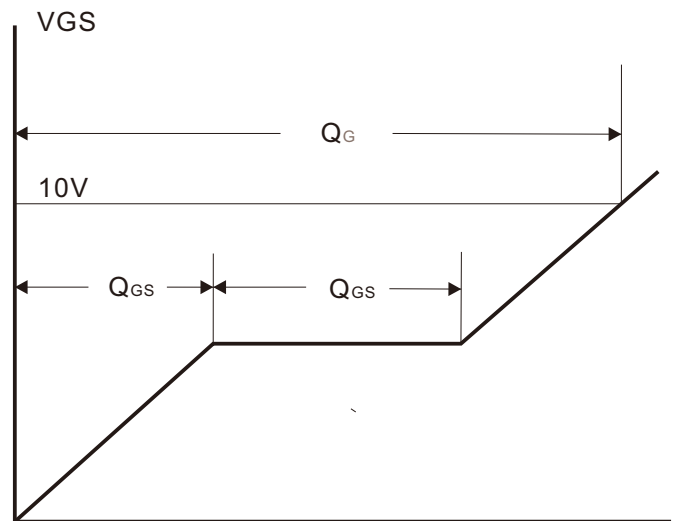

Gate Charge Waveform

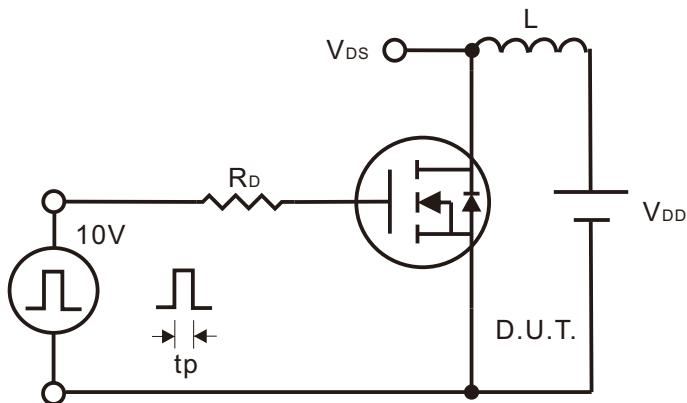

Unclamped Inductive Switching Test Circuit

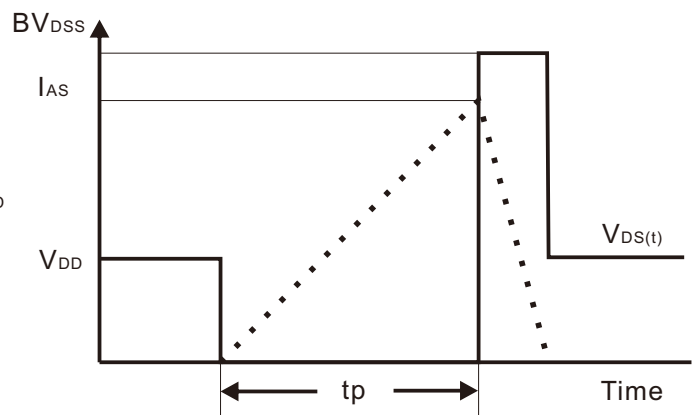

Unclamped Inductive Switching Waveforms

● 特征曲线 TYPICAL CHARACTERISTICS

Output Characteristics

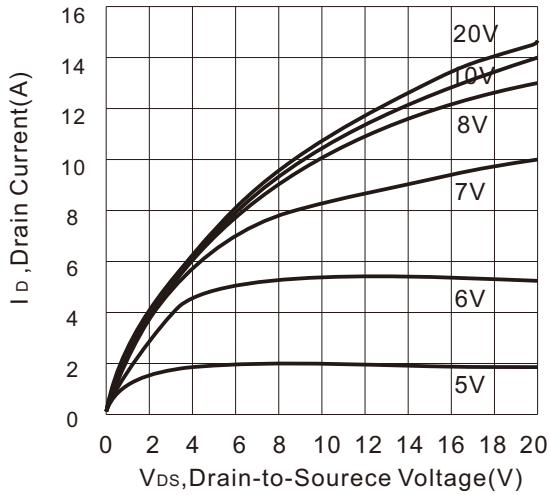

Transfer Characteristics

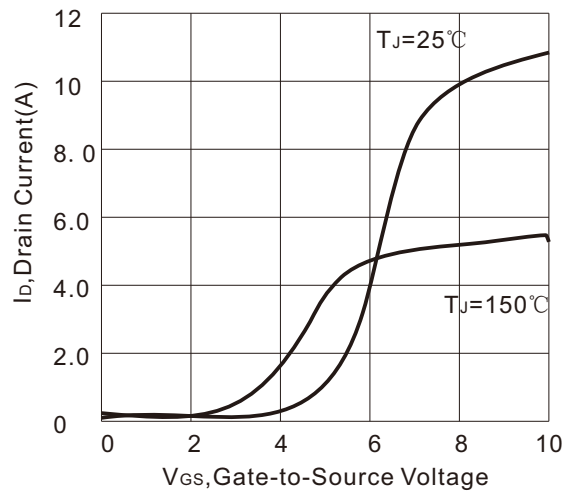

Drain Current VS. Temperature

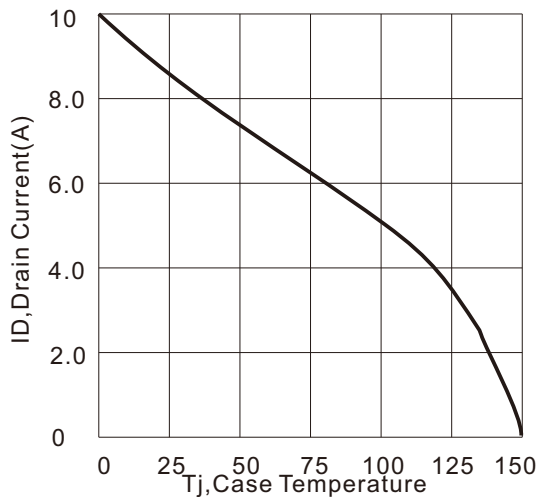

Gate Charge

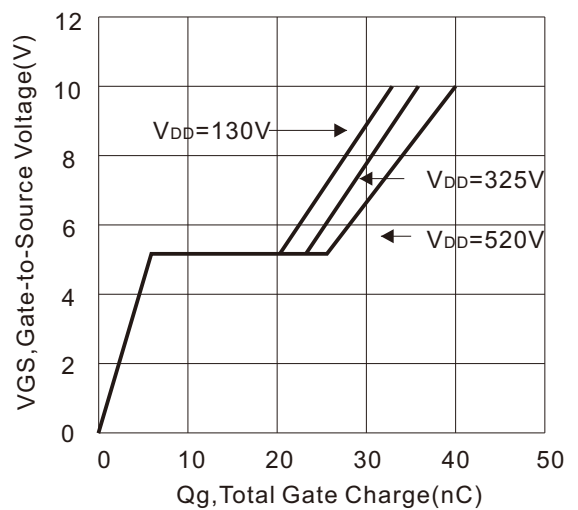

On-Resistance vs. Junction Temperature

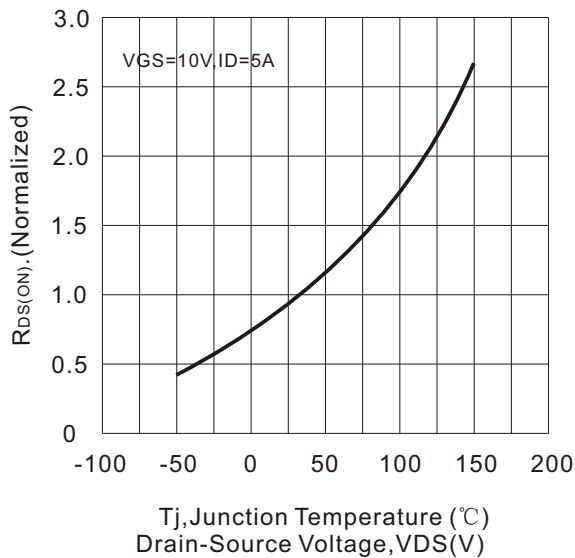

BVDS Variation VS. Temperature

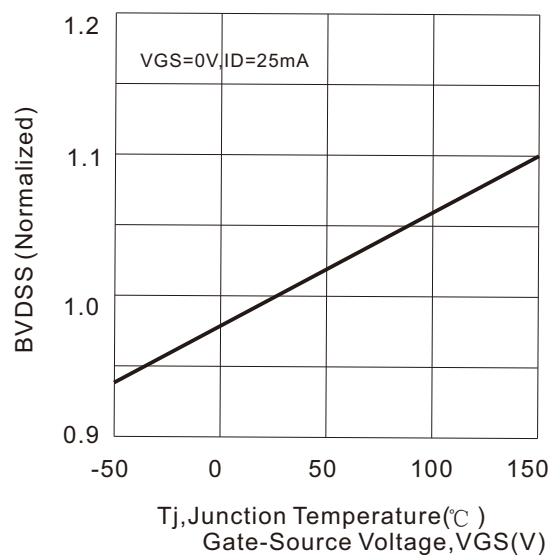

● 特征曲线 TYPICAL CHARACTERISTICS

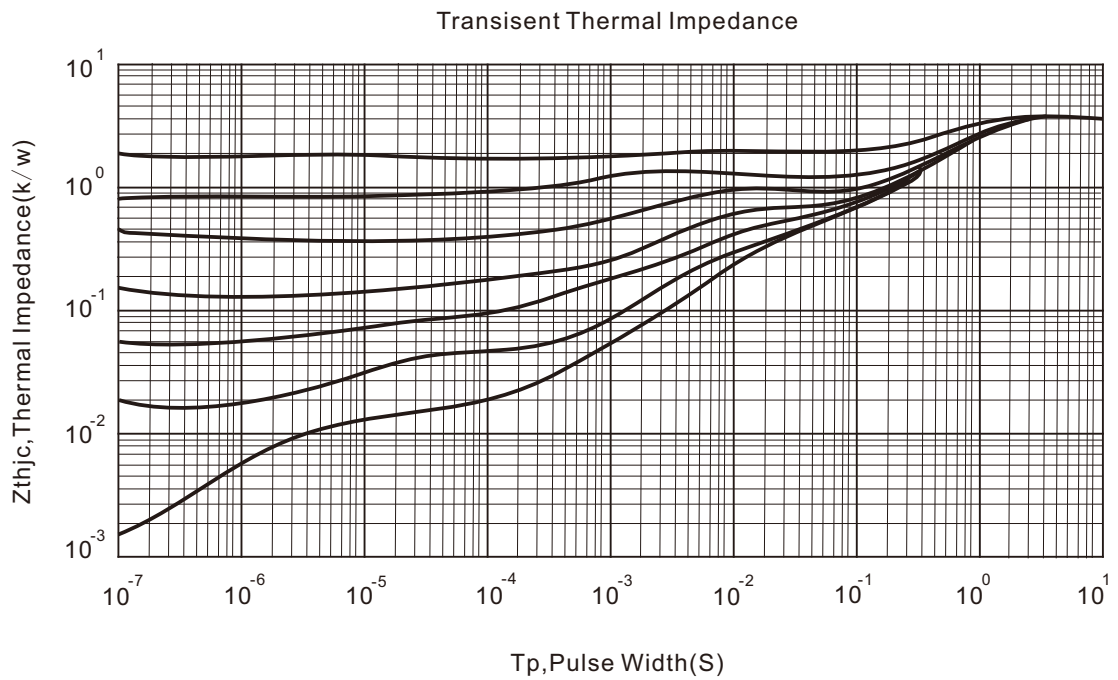
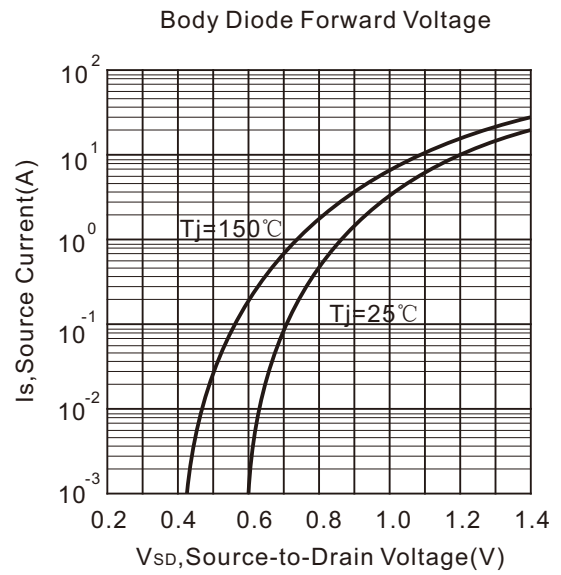
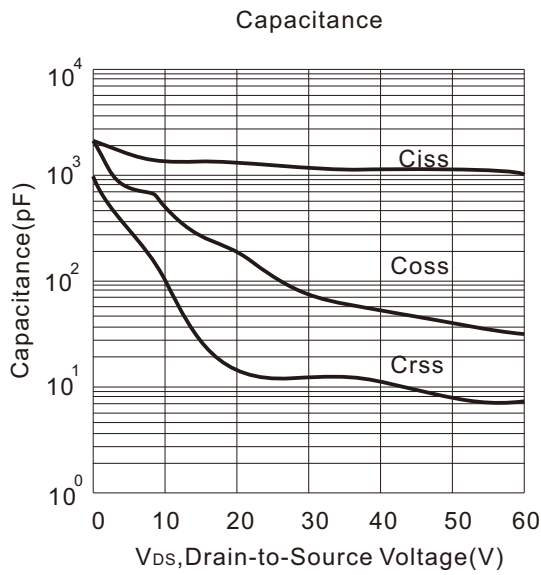

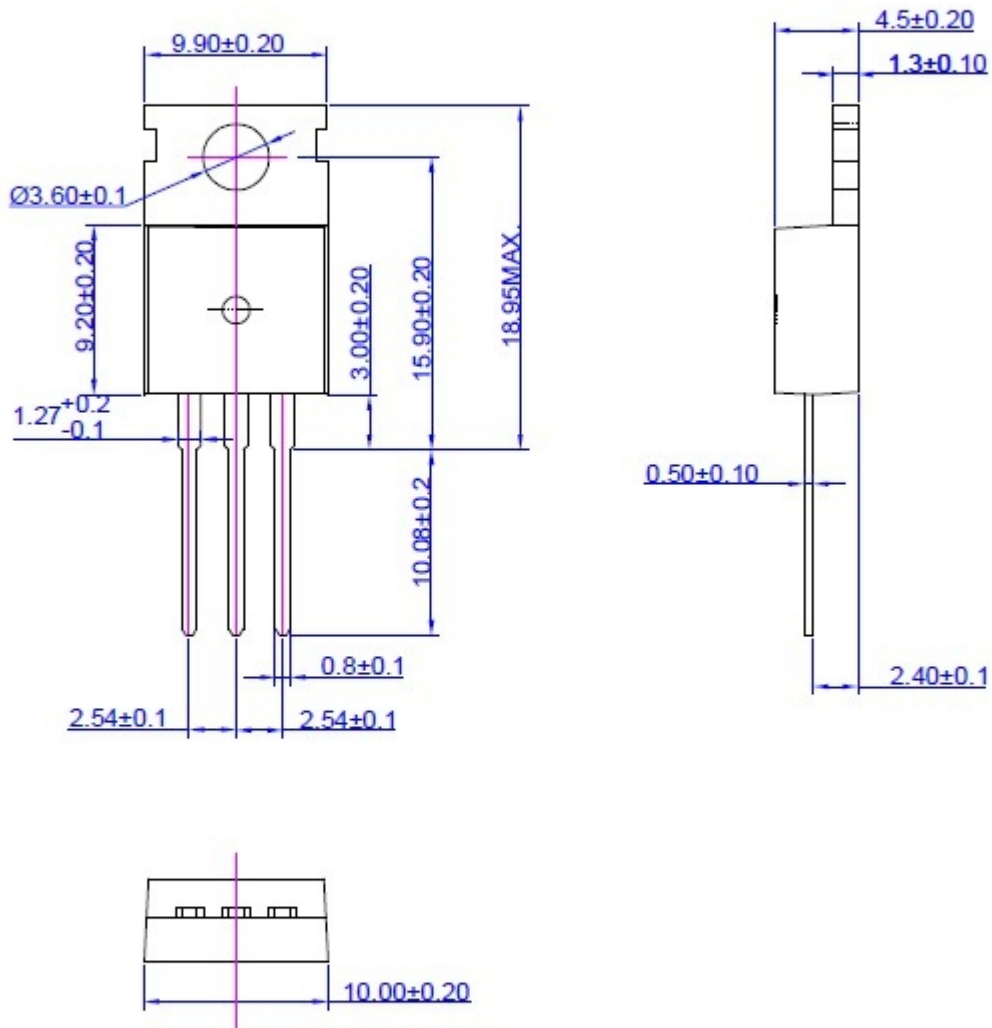

技术要求:

- 1.未注公差 $\pm 0.15 \text{ mm}$;
- 2.树脂体不准有缺损, 缩孔, 裂纹、气泡等有害缺陷
- 3.此图标明管腿有加强筋

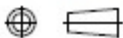
NAME.	TO-220C	UNIT	mm	DESIGNED		THIRD ANGLE SYSTEM 
DWGNO	HW-DT-004c	PAGE	1OF1	CHECKED		
VERSION	Ver.C	ISSUE DATE	Oct/10/2012	APPROVED		

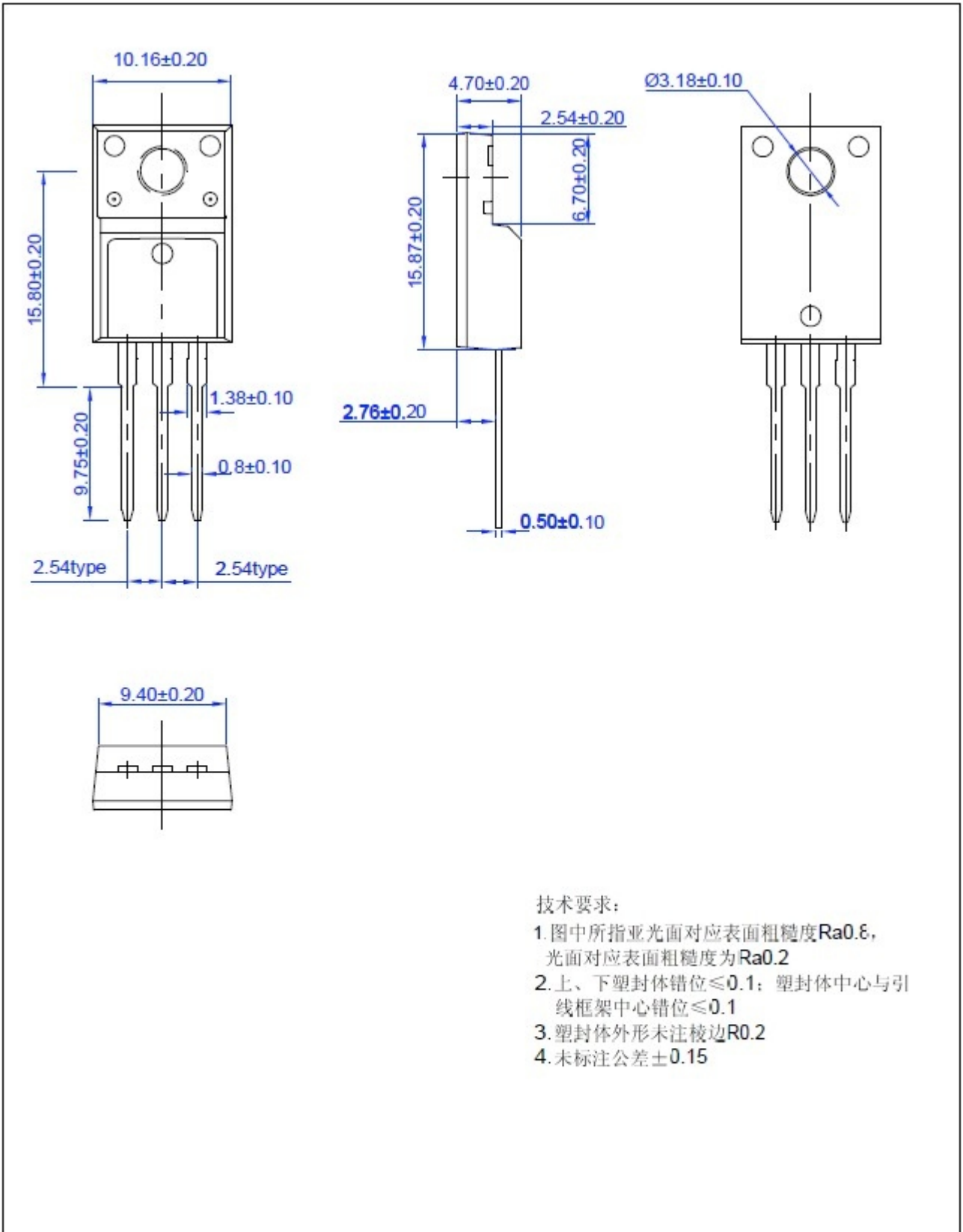

技术要求:

1. 图中所指亚光面对应表面粗糙度Ra0.8, 光面对应表面粗糙度为Ra0.2
2. 上、下塑封体错位 ≤ 0.1 ; 塑封体中心与引线框架中心错位 ≤ 0.1
3. 塑封体外形未注棱边R0.2
4. 未标注公差 ± 0.15

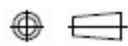
NAME.	TO-220F	UNIT	mm	DESIGNED		THIRD ANGLE SYSTEM 
DWGNO	HW-DT-008c	PAGE	1OF1	CHECKED		
VERSION	Ver.C	ISSUE DATE	Oct/10/2012	APPROVED		